

Technical Bulletin M/L – 699

Foundation Requirements & Installation Instructions for
MRM™ & VPS™
Isolation Elements

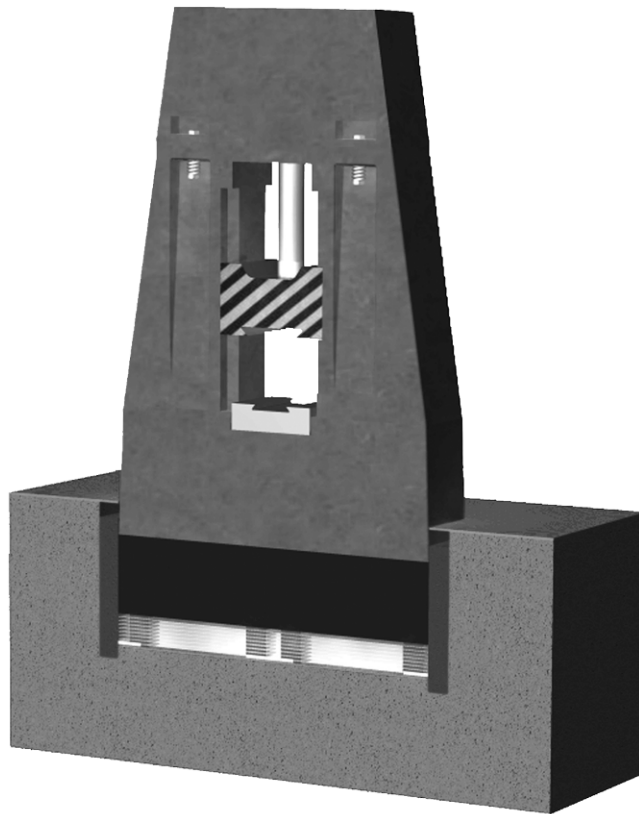

Vibro/Dynamics MRM™ & VPS™ Isolation Systems are an investment in faster, easier hammer installations; increased machine productivity; and an improved work environment for your hard-working personnel. To realize the full potential of your investment, familiarize yourself with these foundation requirements and installation instructions, using them as a reference during the foundation design stages and hammer installation.

© Copyright 2003-2012 Vibro/Dynamics LLC
All Rights Reserved

Call or email us for assistance:
Vibro/Dynamics LLC
2443 Braga Drive
Broadview, IL 60155-3941
Email: vibro@vibrodynamics.com

1-800-842-7668 (in U.S.A.)
1-708-345-2050 Telephone
1-708-345-2225 Fax
www.vibrodynamics.com

Foundation Requirements

1. The concrete surface under the isolation elements must be clean and have a brushed finish. There should not be any holes, cracks, or lumps under the isolation element. Uneven load and force distribution will occur on the MRM or VPS Isolation Elements if the foundation or anvil bottom is not flat.

2. The **flatness** of the foundation under an individual Isolation Elements should not exceed $\pm 1/16$ inches ($\pm 1,6\text{mm}$). When installations require multiple isolation elements, the overall pit flatness should not exceed 0.13" ($\pm 3,2\text{mm}$) corner to corner. See Figure 1. Self-leveling, epoxy grout can be used to repair the surface of the foundation pit. The epoxy grout must have high compression strength and high impact resistance. Please consult the grout manufacturer to determine the best grout for the application. Steel plates placed on the bottom of the pit *are not* recommended.

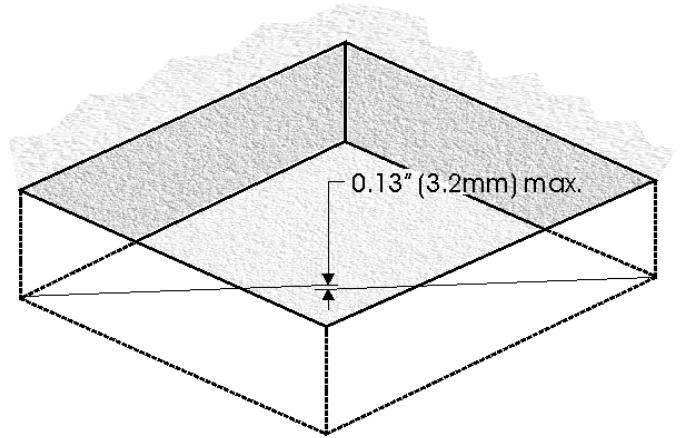

FIGURE 1

3. The **slope** of the foundation under the isolation elements should not exceed $1/8$ " per 10 feet (1mm/m). A slope or tilt greater than this amount may increase vibration levels, machine motion, and overall wear of system.

4. Provisions should be made to remove water and oil from the pit. A drain located in the pit sidewall or bottom and connected to a sump pump is recommended. See Figure 2.

5. To restrict horizontal motion of the anvil base, timbers should line the inside of the foundation walls and be anchored into place. There should be $1/32$ " to $1/16$ " clearance between the anvil base and the timbers. The anvil base should not be supported by or sit on top of any of the side timbers. See Figure 2.

(Min. recommended timber size: 4" x 4" or 100mm x 100mm).

Plumbing for a sump pump connected to a drain in the bottom or side of the pit is recommended for removal of water and oil.

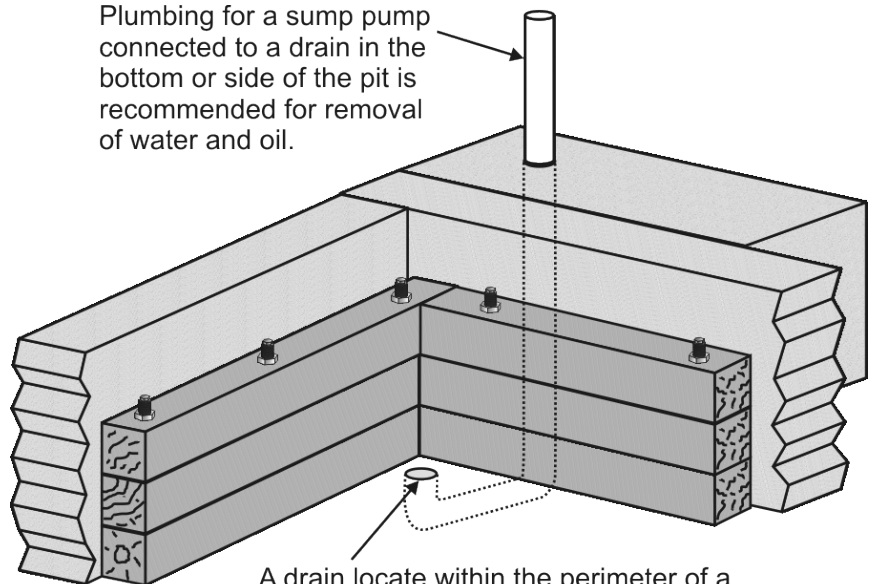

A drain locate within the perimeter of a MRM Element may be desirable to keep heavy debris from clogging the pipe.

FIGURE 2

6. The MRM/VPS isolation systems are designed to move freely and without obstruction in response to a hammer blow. Precautions should be taken to keep slag and debris from getting into the MRM/VPS System. If debris is allowed to collect in the pit in large quantities, solid materials commonly found in the forging environment can decrease the effectiveness of the MRM/VPS System. The following steps should be considered when preparing for hammer installation.

7. For foundation designs **not using backfill**, see Figure 3 for foundation guidelines.

8. For foundation designs **using backfill** (Figure 4), extra precautions are highly recommended:

- Galvanized sheet should be installed around the anvil base perimeter, between the MRM/VPS Isolation Elements and the timbers. The galvanized sheet should extend above the bottom of the anvil base.
- A polyethylene liner should also be installed around the perimeter of the anvil base and underneath the backfill.

9. Clean and inspect the anvil base. Repair all cracks and any damage. The bottom of the anvil *must* be clean and flat where it contacts the top of the isolation elements. Uneven load and force distribution will occur on the isolation elements if foundation or anvil bottom are not flat. See Steps 2 & 3 for tolerances.

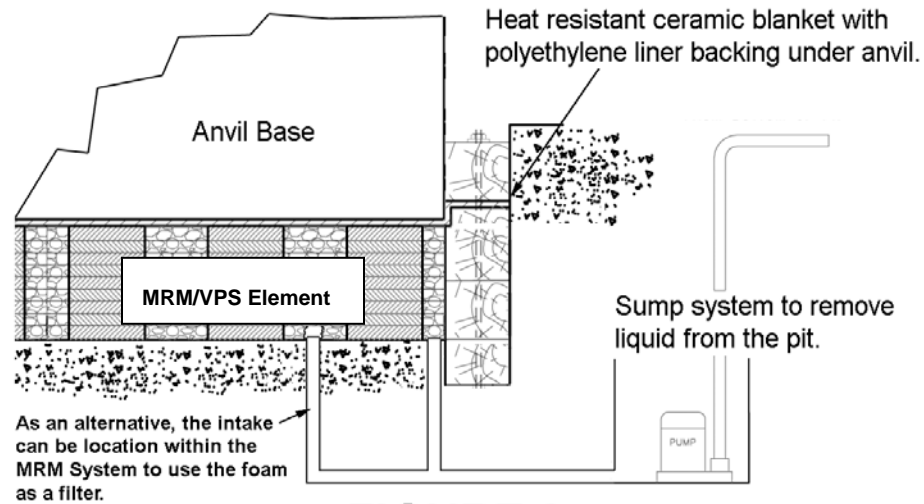

FIGURE 3

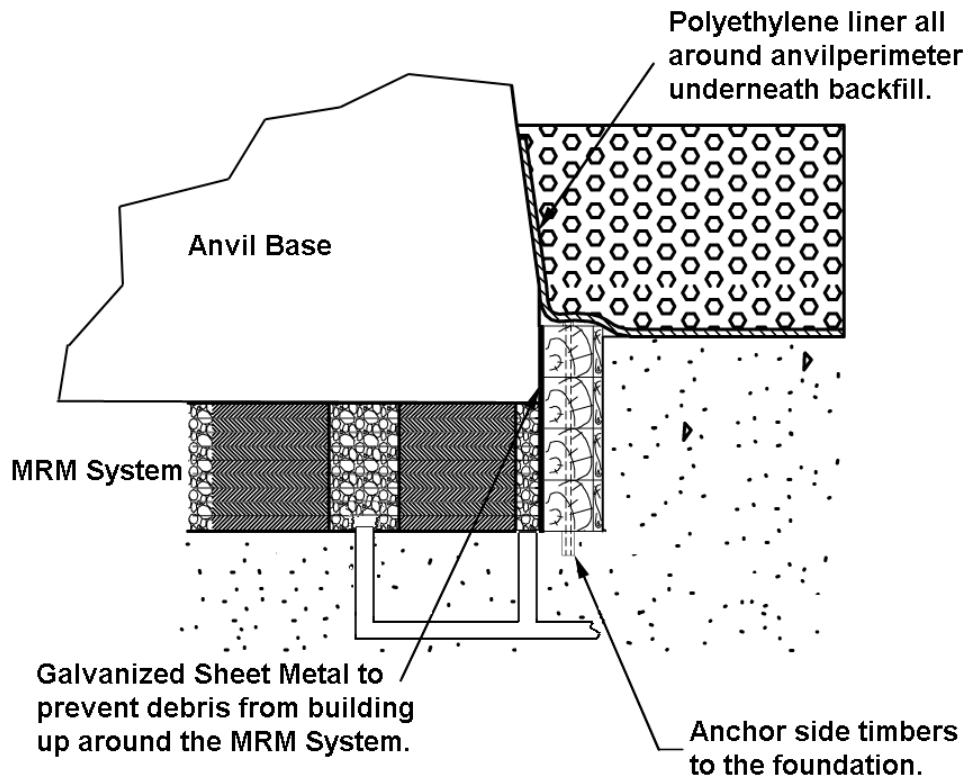

FIGURE 4

Isolation Element Installation

10. Do not remove the Protective Foam Barrier! This is designed to prevent debris from getting into the system.
11. The isolation elements should be lifted and installed into the foundation pit using the two supplied 3/4-10 UNC or 20mm x 2.5 eyebolts and couples. See Figure 5. The number of eyebolts required will depend on the physical size of the isolation elements.
Caution: Do not attempt to lift by wrapping chains or straps around the isolation elements.
12. If multiple isolation elements are used under an anvil, the elements may be numbered. Position them in the pit according to the installation drawing.
13. Lower and center the anvil base on the isolation elements. All elastomer elements should be covered by the anvil base. See Figure 6.
14. Complete the hammer assembly.
15. Use caution when welding near Isolation Elements since the Barrier Foam can catch fire.
16. After the hammer is running, check for any interference or isolation short-circuits.

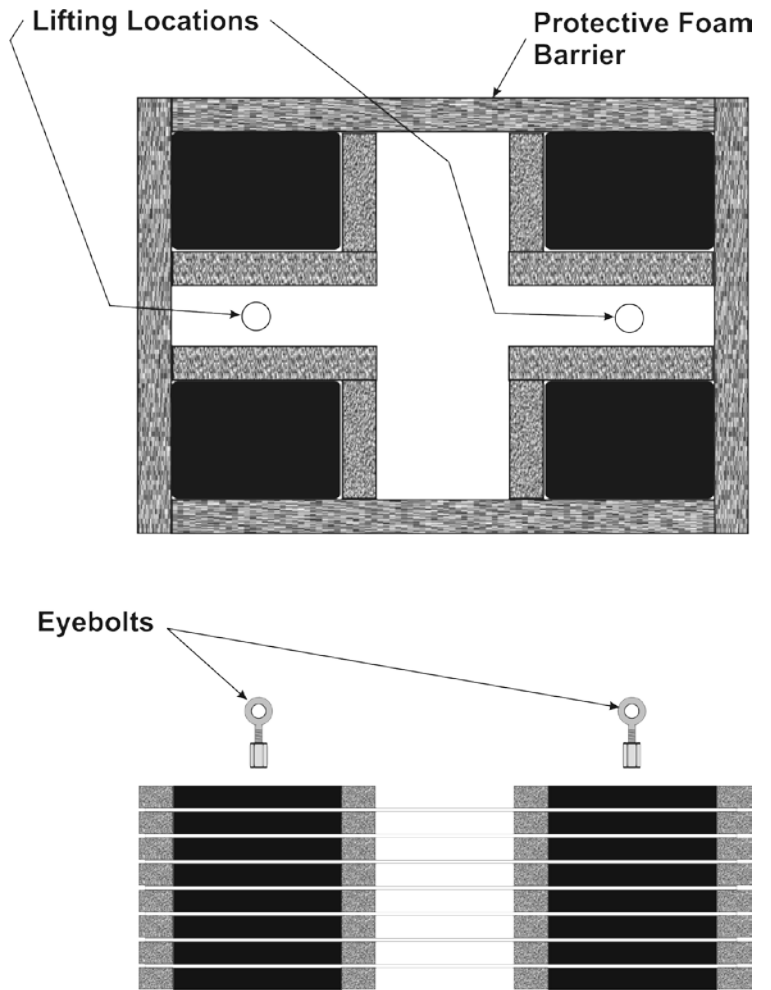

FIGURE 5

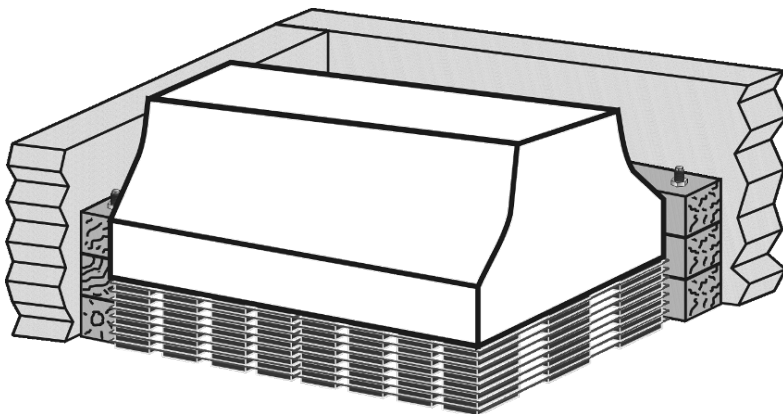
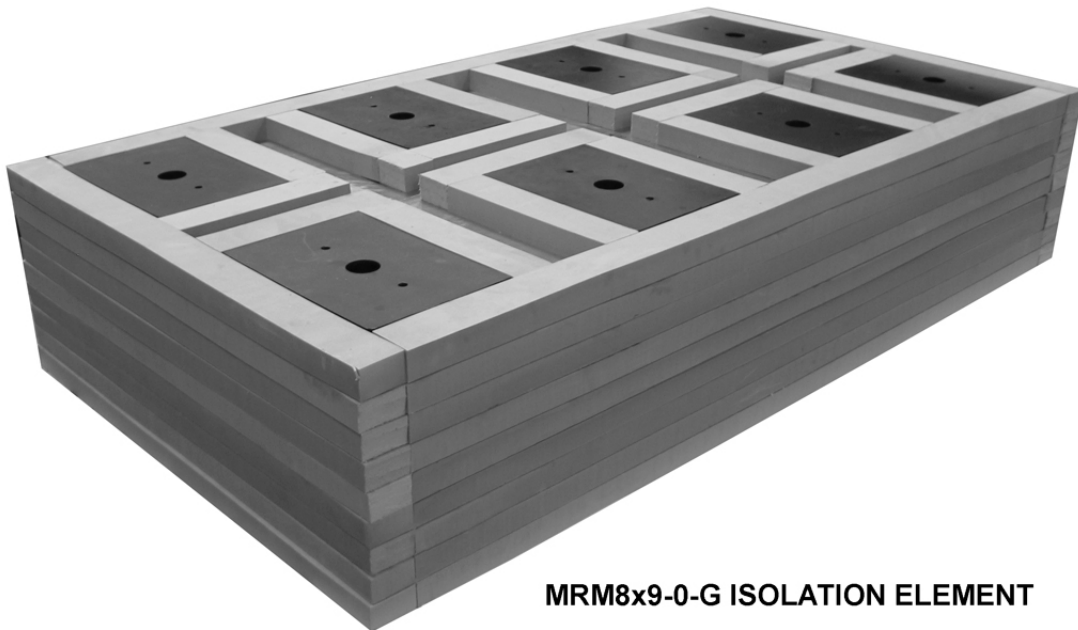

FIGURE 6

Preventative Maintenance

17. There should not be any **solid connections** between the machine and the foundation or building structure. **Flexible connections** are recommended for plumbing and electrical conduit. Floor plates, walkways, railings, etc. should not be attached to both the machine and the floor, foundation or building. Hard connections will “**short-circuit**” isolation effectiveness.
18. The foundation pit should be kept **clean and dry**. Scrap and slag should be periodically removed from areas around the anvil.
19. Monitor the anvil base for any elevation and slope changes. Some settling over time is expected and normal. Consult the original installation drawing for predicted levels.
20. The isolation elements are heat tolerant to 250 degrees Fahrenheit. Long term exposure to temperatures greater than 150 degrees will shorten the life of the MRM/VPS System. Exercise caution when welding near the MRM/VPS Elements since the Barrier Foam can catch fire. Use a ceramic blanket or other protective measure(s).
21. Caution should be taken when performing any weld repair to anvil bases.



MRM8x9-0-G ISOLATION ELEMENT

For Assistance, please contact Vibro/Dynamics LLC
Telephone: 1 800 842 7668 and 708 345 2050
Email: vibro@vibrodynamics.com